

REAR SUSPENSION

The ATC200X has a shock absorber with two adjustments for the rider's weight and riding conditions. The spring adjuster nut (1) adjusts spring preload for changes in the rider's weight.

The rebound damping adjuster (3) adjusts damping from soft to firm to provide the desired ride with changes in the rider's weight and riding conditions.

CAUTION:

* *Make sure the engine is off and the parking brake is applied before adjusting the rear suspension.*

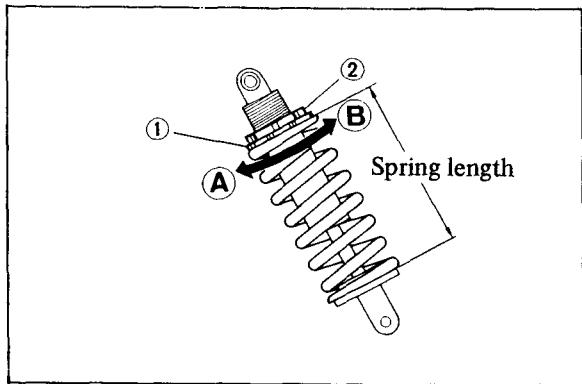

- (1) Adjuster nut (A) Increase
(2) Lock nut (B) Decrease

To adjust spring preload:

1. Remove the seat/rear fender by sliding the lever.
2. Place a support under the engine to raise the rear wheel off the ground.
3. Measure the spring length.
Standard: 195 mm (7.7 in)
Minimum: 190 mm (7.5 in)
Maximum: 200 mm (7.9 in)
4. To adjust preload, loosen the lock nut (2) with a pin spanner and turn the adjuster nut (1).

NOTE:

- * An optional pin spanner for adjusting the rear suspension is available at your authorized Honda dealer.
5. Tighten the lock nut and measure the spring length again, make sure the adjustment is within the minimum or maximum allowable adjustment length. Reinstall the seat /rear fender, making sure they are securely attached.