

# MAJOR COMPONENTS (Information you need to operate this motorcycle)

## ▲ WARNING

• If the Pre-ride Inspection (page 62) is not performed, severe personal injury or vehicle damage may result.

## SUSPENSION

### Front Suspension

#### Spring preload:

Adjust the spring preload by turning the preload adjuster (1) with the 22 mm wrench provided in the tool kit.

To reduce (SOFT) :

Turn the adjuster counterclockwise toward SOFT for a light load and smooth road condition.

To increase (HARD) :

Turn the adjuster clockwise toward HARD for a firmer ride and rough road condition.

#### Standard position:

To return to the standard position, turn the adjusters until the 4th groove from the top aligns with the top surface of the fork caps.

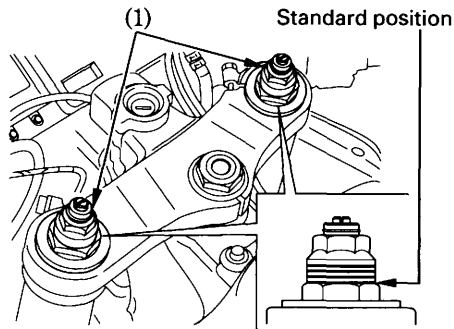

(1) Preload adjuster