

## If a Fuse Blows

All of the electrical circuits on your CRF have a fuse to protect them from damage caused by excess current flow (short circuit or overload).

If something electrical on your CRF stops working, the first thing you should check for is a blown fuse. Check the fuse before looking elsewhere for another possible cause of the problem. Replace a blown fuse and check component operation.

- The main fuse (and spare) are located on the starter magnetic switch behind the right side cover.

### Recommended Main Fuse: 15A

1. To prevent an accidental short circuit, stop the engine.
2. Remove the seat mounting bolt (1), right side cover bolt (2), collar (3) and right side cover (4).

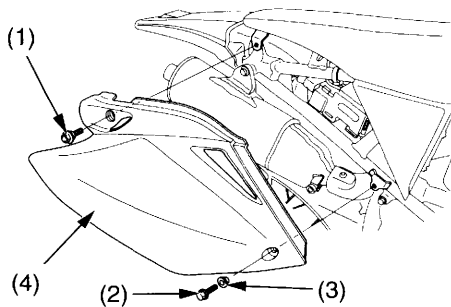

- (1) seat mounting bolt
- (2) right side cover bolt
- (3) collar
- (4) right side cover

3. Disconnect the wire connector (5) of the starter magnetic switch (6).
4. Pull main fuse (7) out. If it is blown (8), install the spare main fuse (9).

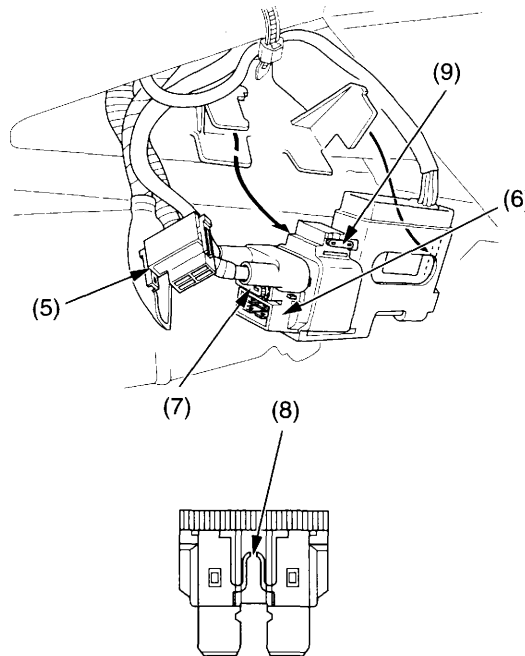

- (5) wire connector
- (6) starter magnetic switch
- (7) main fuse
- (8) blown fuse
- (9) spare main fuse

5. Reconnect the wire connector.

If you do not have a replacement fuse with the proper rating for the circuit, install one with a lower rating.

### **NOTICE**

*Replacing a fuse with one that has a higher rating greatly increases the chance of damage to the electrical system.*

If you replace a blown fuse with a spare fuse that has a lower rating, replace the fuse with the correct rating as soon as you can. Also remember to replace the spare fuse that was installed.

If the replacement fuse of the same rating burns out in a short time, there is probably a serious electrical problem on your CRF.

Leave the blown fuse in that circuit and have your CRF checked by your Honda dealer.