

# Riding in Reverse

If you need to ride in reverse, make sure the area behind you is clear and only operate the ATV at low speed.

Your ATV is equipped with a reverse speed limiter and reverse gear rev limiter to assure low operating speed while backing up.

## **⚠ WARNING**

Improperly operating in reverse could cause you to hit an obstacle or person behind you, resulting in serious injury.

Make sure there are no obstacles or people behind you before selecting reverse gear. When it is safe to proceed, go slowly.

1. Bring the vehicle to a complete stop, pull in the clutch lever/parking brake lever (1) and depress the shift lever (2) to shift into 1st gear.
2. Depress and hold down the rear brake pedal.
3. Be sure there are no obstacles or people in the way.

LEFT HANDLEBAR

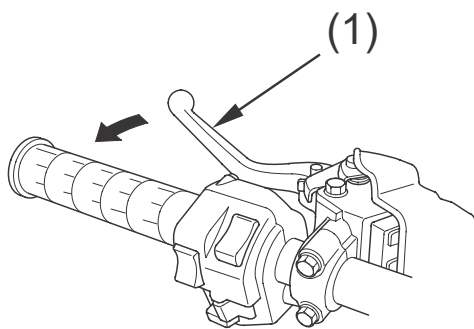

(1) clutch lever/  
parking brake lever

LEFT SIDE

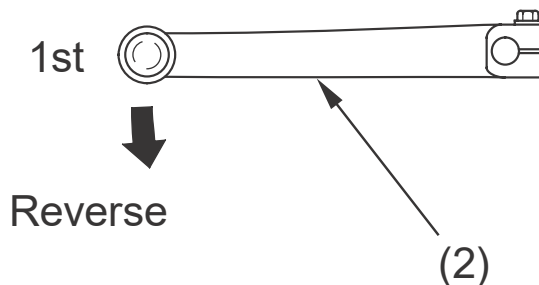

(2) shift lever

(cont'd)