

Tyre Puncture ► Removing Wheels

5. Remove the front axle bolt.
6. Loosen the right axle pinch bolt.
7. Support your motorcycle securely and raise the front wheel off the ground using a maintenance stand or a hoist.

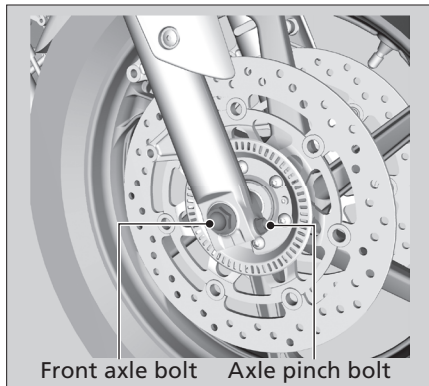

8. Loosen the left axle pinch bolt.
9. On the left side, withdraw the front axle shaft, and remove the side collars and wheel.

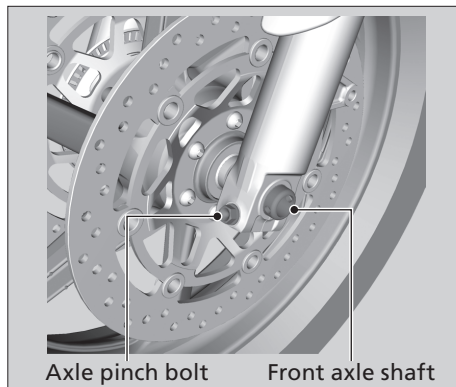

Troubleshooting