

Starting cont:

-WHEN THE ENGINE IS WARM

1. Check the handle lock is released.
2. Confirm that the fuel cock lever is switched to "ON".
3. Turn the ignition switch "ON".
4. Place the transmission in neutral (confirm this with the neutral display lamp).
5. Turn the throttle grip between $1/8$ ~ $1/4$ and then firmly kick start the motorcycle.
6. Adjust engine RPM to a smooth level by the throttle.
7. Make sure that the side stand is properly housed away before riding.

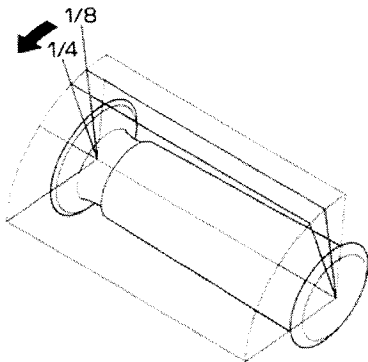

-Refer to the instructions outlined on page 85 if the engine fails to start.