

Installation

Install the parts in the reverse order of removal. Always connect the positive ⊕ terminal first. Make sure that bolts and nuts are tight.

Make sure the clock information is correct after the battery is reconnected. ► P. 78

For proper handling of the battery, see "Maintenance Fundamentals." ► P. 143
"Battery Goes Dead." ► P. 207

Cylinder Head Side Cover

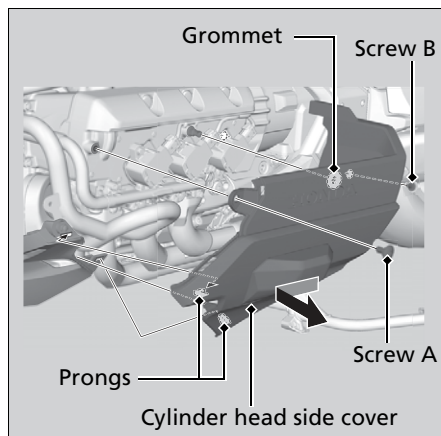

The right and left cylinder head side cover can be removed in the same way.

Removal

1. Remove the fog light cover. ► P. 155
2. Remove the screw A and B.
3. Remove the prongs from the lower cover.
4. Pull the grommet from the boss on the cylinder head and slide the cylinder head side cover forward, then remove it.

Installation

Install the parts in the reverse order of removal.