

# System Start-up

## System Failure to Display a Position Fix

If the receiver does not get a position fix within about 8 minutes (flashing antenna mark (1) as shown in the illustration), make sure there are no overhead obstructions (building, trees, canopy, etc.) and then perform the following:

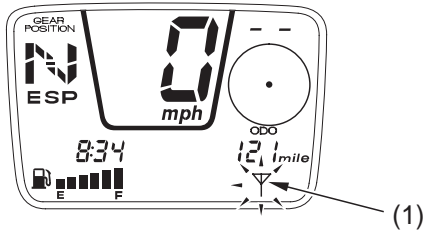

(1) antenna mark

1. Turn the ignition switch OFF (O).
2. Remove the battery cover (2) by removing the bolts (3).
3. Disconnect the negative (-) terminal lead (4) from the battery (5) and wait for 1 minute.

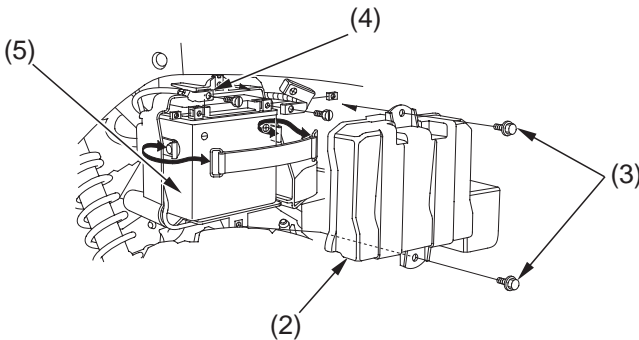

(2) battery cover  
(3) bolts

(4) negative (-) terminal lead  
(5) battery