



DTC 29-1 (IACV)



• Fuel tank shroud →3-6

IACV Diagram

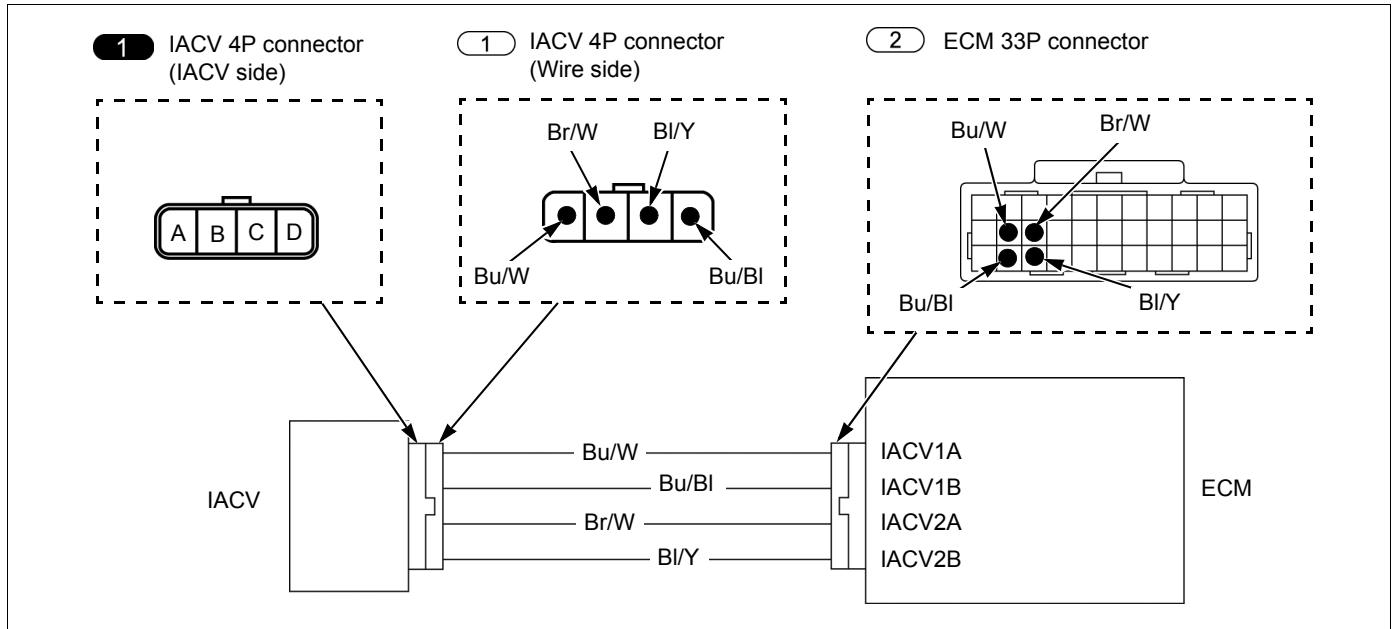

1. IACV System Inspection

- Check the IACV with MCS.
- Is the DTC 29-1 is indicated?

No
▶

- Intermittent failure
- Loose or poor contact at the connector

Yes ▼

2. IACV Circuit Inspection

- Check a open or short circuit in Bu/W, Br/W, Br/BI and Bu/BI wires.
- Is there open or short circuit?

Yes
▶

- Faulty Bu/W, Br/W, BI/Y or Bu/BI wire

No ▼

3. IACV Resistance Inspection

- Connection: A – D, B – C
- Is the resistance within 110 – 150 Ω (25 °C)?

No
▶

- Faulty IACV

Yes ▼

4. IACV Short Circuit Inspection

- Connection: A – B, C – D
- Is there continuity?

Yes
▶

- Faulty IACV

No ▼

- Replace the ECM with a new one →4-19, and re-check.