

Remove the front balancer shaft holder pinch bolt. Turn the front balancer shaft clockwise until the resistance is felt, then back it off one graduation using the punch mark as a measure.

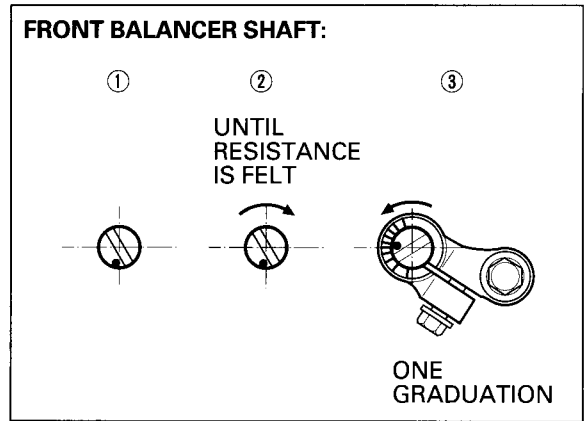

Warm up the engine and let it idle.

If the balancer gear noises excessive, adjust the balancer backlash as follows:

1. Turn the rear balancer idle gear shaft clockwise until the gears begin to make a "whining" noise. Then, turn the gear shaft counterclockwise until the gear "whine" noise disappears.

Tighten the gear shaft pinch bolt to the specified torque.

**TORQUE:** 12 N·m (1.2 kgf·m , 9 lbf·ft)

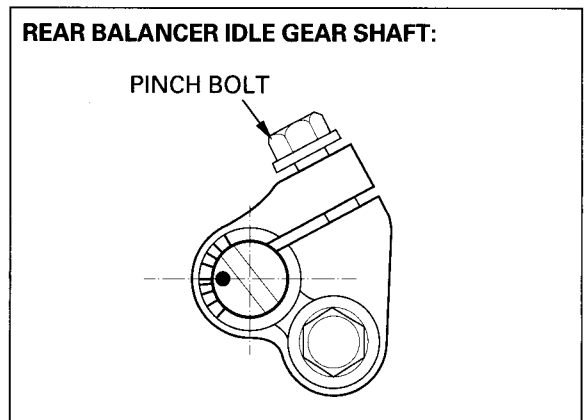

2. Turn the rear balancer shaft counterclockwise until the gears begin to make a "whining" noise. Then, turn the gear shaft clockwise until the gear "whine" noise disappears.

Tighten the gear shaft pinch bolt to the specified torque.

**TORQUE:** 12 N·m (1.2 kgf·m , 9 lbf·ft)

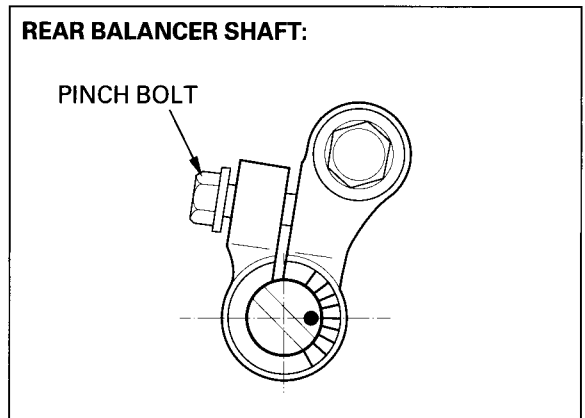

3. Turn the front balancer shaft clockwise until the gears begin to make a "whining" noise. Then, turn the gear shaft counterclockwise until the gear "whine" noise disappears.

Tighten the gear shaft pinch bolt to the specified torque.

**TORQUE:** 12 N·m (1.2 kgf·m , 9 lbf·ft)

After all gear backlash adjustments are done, snap the throttle and make sure the gear noises is not excessive.

If the gear "whine" noise is excessive, the backlash is too small.

If the gear "rattling" noise is excessive, the backlash is excessive.

